

NTEP APPROVED PALLET TRUCK WITH SCALE, PM-2746-TL-SCL-LP

NOTE:
THIS PRODUCT MAY NOT FIT
SOME STANDARD PALLETS

MIN LOWERED HT 3^{1/8}"

PLEASE VERIFY YOUR
MINMUM HT

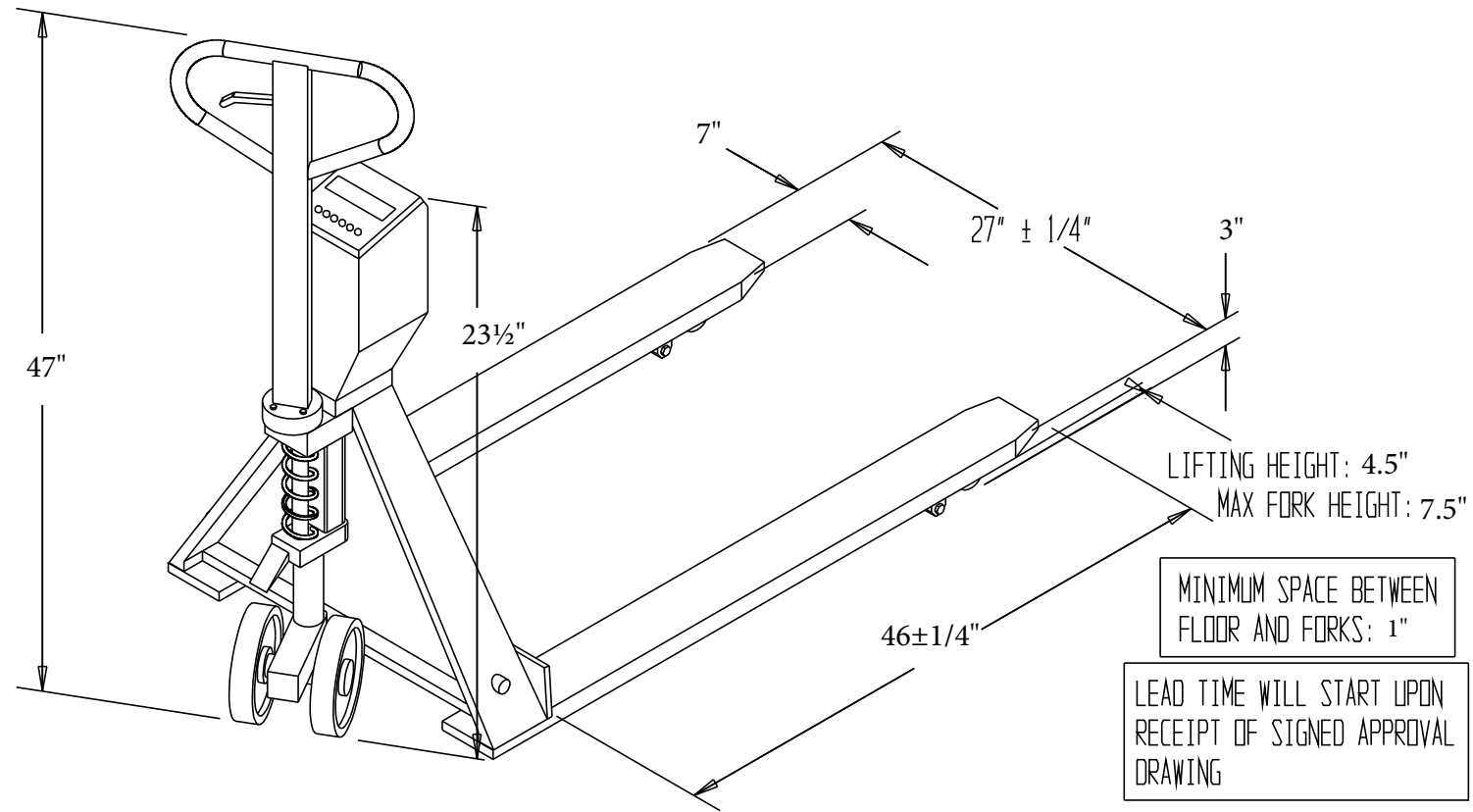

**SPECIAL UNITS ARE NON-RETURNABLE
*AVAILABLE AT ADDITIONAL COSTS

STANDARD FEATURES

MODEL NUMBER: PM-2746-TL-SCL-LP
OVERALL LENGTH OF FORKS IS 46 ± 1/4 INCHES
OVERALL WIDTH OF FORKS IS 27 ± 1/4 INCHES
LOWERED HEIGHT OF 3^{1/8} INCHES
RAISED HEIGHT OF 7 1/2 INCHES
CAPACITY IS 5,000 LBS.
POLYURETHANE WHEELS
WEIGHT SCALE MOUNTED ON UNIT

SPECIAL FEATURES

NONE

NOTE: GRAPHICS MAY NOT BE TO SCALE

**Any additions, deletions or omissions must
be corrected on this drawing, as this drawing
will be considered all inclusive.**

*** ALL GRAPHICS PROVIDED ARE FOR REFERENCE ONLY. IF CERTAIN DIMENSIONS
ARE CRITICAL PLEASE VERIFY THOSE DIMENSIONS WITH YOUR SALESPERSON. ***

A P P R O V A L	I, THE UNDERSIGNED, AGREE THAT THE PRODUCT AS REPRESENTED SATISFIES DESIGN & DIMENSION REQUIREMENTS. I ALSO ACKNOWLEDGE MY DUTY TO CONFIRM PRODUCT & INSTALLATION COMPLIANCE WITH ALL APPLICABLE FEDERAL, STATE AND LOCAL REGULATIONS & STANDARDS.	
	ALL SPECIAL UNITS ARE NON-RETURNABLE	
	[] As drawn [] As marked	
	Signed: _____	Date: _____
LEAD TIME WILL START UPON RECEIPT OF SIGNED APPROVAL DRAWING		

DISTRIBUTOR'S NAME: VESTIL MFG		P.O.#: _
DRAWN BY: TM		DATE: 05/31/2019
REFERENCE: _	SCALE: _	SALES: _
QUOTED LEADTIME: _	QUOTE #: _	DRWG./FILE NAME: